

# 8900 T/TH

Track pull side mount and backplate (BP89)  
with optional hold open (TH)

## Installation instructions

08280121 – 09-2019

| EN |

dormakaba 

# Table of contents

|          |  |          |
|----------|--|----------|
| <b>1</b> | <b>Technical specifications</b>                                | <b>3</b> |
| 1.1      | Overview   | 3        |
| 1.2      | Tools recommended  | 3        |
| 1.3      | Handing the door   | 3        |
| <b>2</b> | <b>Instructions - track mount</b>                              | <b>4</b> |
| 2.1      | Installing backplate and surface closer                        | 4        |
| 2.2      | Assemble and secure track                                      | 4        |
| 2.3      | Securing main arm to closer                                    | 5        |
| <b>3</b> | <b>Adjustments</b>   | <b>6</b> |
| 3.1      | Adjust closing speeds: sweep, latch, backcheck, delayed action | 6        |
| 3.2      | Adjust hold open (optional)                                    | 6        |
| 3.3      | Adjust spring force  | 7        |
| <b>4</b> | <b>Install covers</b>  | <b>7</b> |

# 1 Technical specifications

## 1.1 Overview

-  Caution: sex nuts are required for attachment of components to unreinforced doors and to wood or plastic faced composite type fire doors, unless an alternative method is identified in the individual door manufacturer’s listings.
-  Maximum door opening degree is 180°.
-  Arrow on backplate points downward.
-  Hold open range is from 80° to 160° with optional hold open kit.

-  Know the swing of the door which is being installed prior to installation.
-  Verify closer spring size prior to installation.
-  Make sure door efficiently operates prior to installing closer.

## 1.2 Tools recommended

Table 1

|                                    |                             |
|------------------------------------|-----------------------------|
| Drill bits:                        | #3 Phillips screwdriver     |
| Metal: 7/32" drill bit; 1/4-20 tap | 3/16" flat head screwdriver |
| Wood: 3/8" and 5/32" bit           | 5mm hex key                 |
| 1/2" box wrench                    |                             |

## 1.3 Handing the door

Fig.1

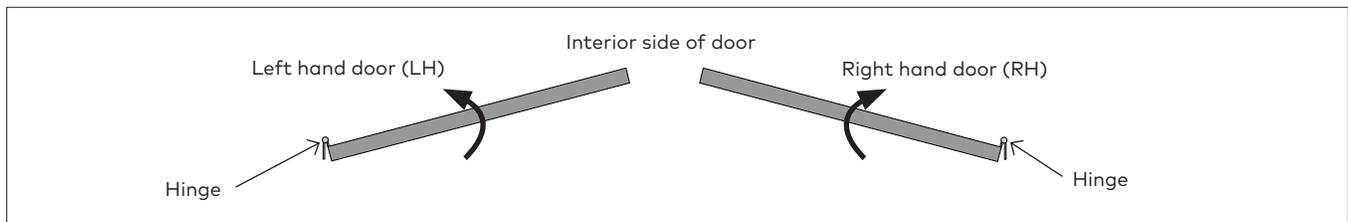

# 2 Instructions - track mount

## 2.1 Installing backplate and surface closer

Fig.2

2.1.1 Reference template 08280122 and 08280123.

2.1.2 Secure backplate. Arrow points downward.

2.1.3 Secure closer body.  
**NOTE: Ensure pinion is oriented away from hinge.**

## 2.2 Assemble and secure track

Fig.3

2.3.1 Attach arm to slide shoe using screw supplied.

2.3.2 Tighten securely.

2.3.3 Insert slide shoe, rubber stop, hold open mechanism (if necessary), and end blocks into track.

2.3.4 Secure track to door.

**NOTE: TH units only: Hold open mechanism and slide shoe must be installed with arrows pointing AWAY from the door hinges.**

**NOTE: Mounting screws pass through end blocks.**

**NOTE: For 180° openings, assemble track without rubber stop.**

## 2.3 Securing main arm to closer

Fig.4

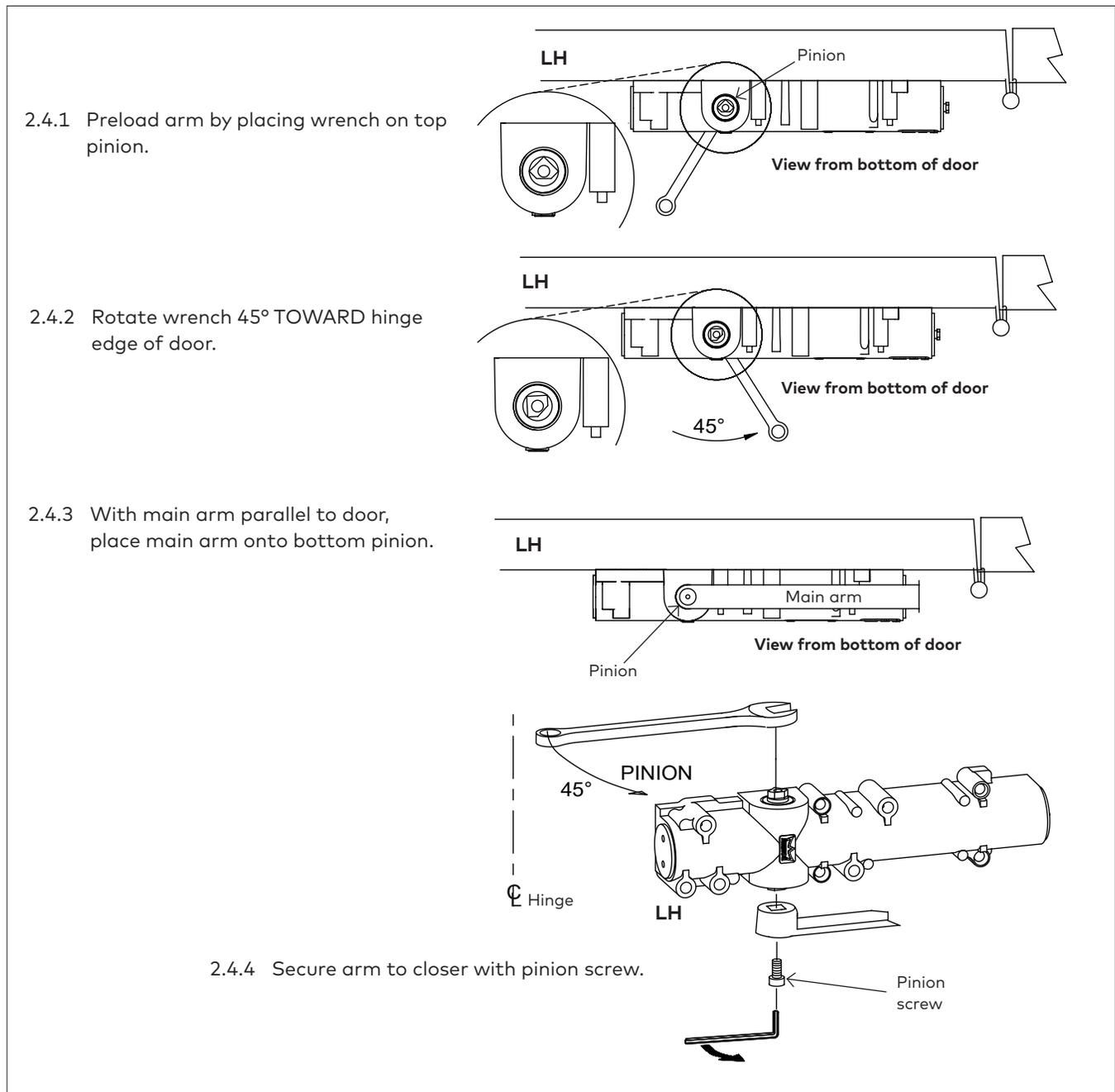

# 3 Adjustments

-  Confirm closer spring size prior to making any closing speed adjustments.
-  Do not back valve heads out beyond closer casting.

-  Maximum opening angle is 80° - 160°.
-  Door should close in 3 to 6 seconds from 90°.
-  Do not close valves completely.

## 3.1 Adjust closing speeds: sweep, latch, backcheck, delayed action

Fig.5

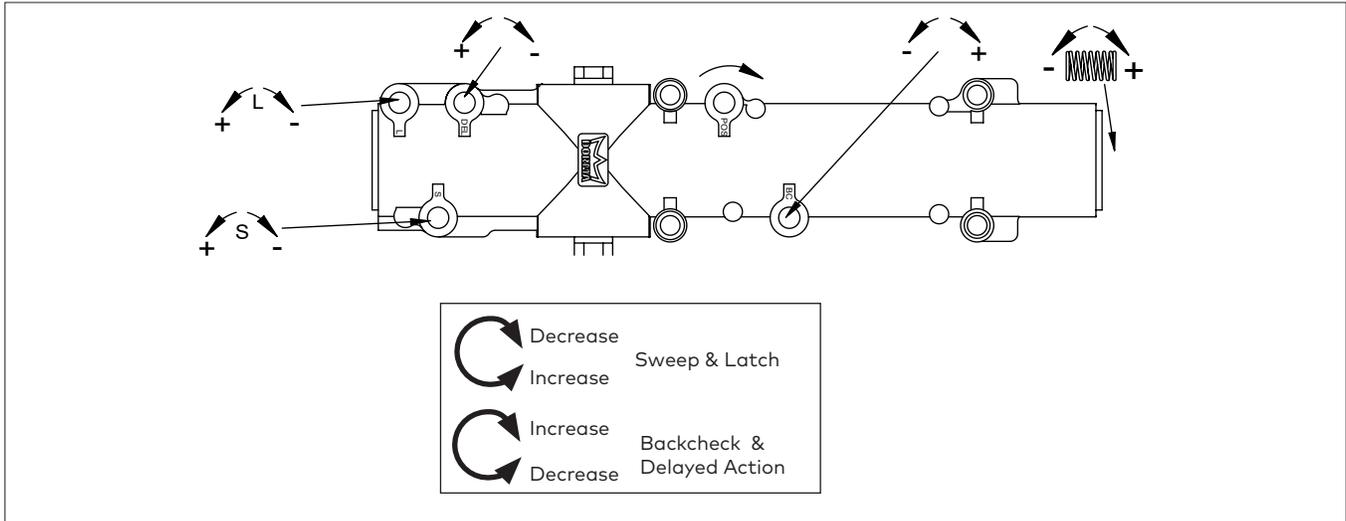

- 3.1.1 Adjust **closing sweep speed**: 90° to start of latch speed.
- Increase sweep speed: Turn valve counter-clockwise
  - Decrease sweep speed: Turn valve clockwise.
- 3.1.2 Adjust **closing latch speed**: 15° to close.
- Increase latch speed: Turn valve counter-clockwise

- 3.1.3 Adjust **opening backcheck**: beginning at 70°.
- Increase resistance: Turn valve clockwise
  - Decrease resistance: Turn valve counter-clockwise.
- 3.1.4 Adjust **closing delayed action**: beginning at 180°.
- Increase delayed action: Turn valve clockwise
  - Decrease delayed action: Turn valve counter-clockwise

## 3.2 Adjust hold open (optional)

Fig.6

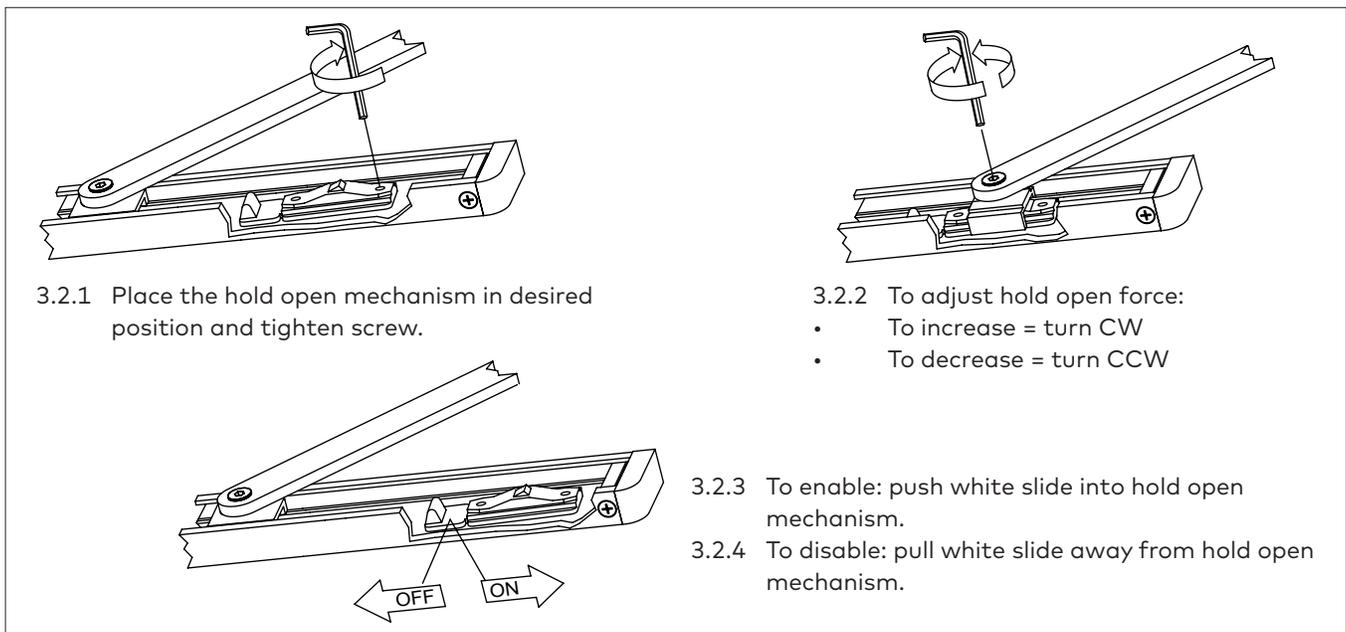

3.2.1 Place the hold open mechanism in desired position and tighten screw.

- 3.2.2 To adjust hold open force:
- To increase = turn CW
  - To decrease = turn CCW

3.2.3 To enable: push white slide into hold open mechanism.

3.2.4 To disable: pull white slide away from hold open mechanism.

### 3.3 Adjust spring force

Fig.7

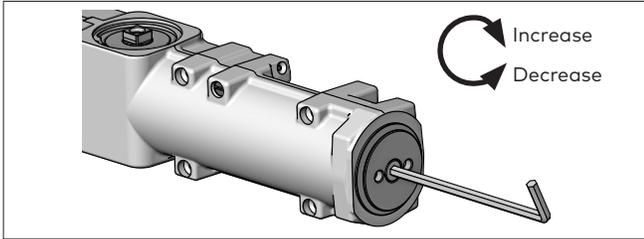

**8916 - supplied with a size 4**  
**8956 - supplied with a size 6**

**8916 ONLY - Barrier free openings:** Take an opening force reading from the pull on the door. If required, adjust the spring force to meet the barrier-free requirement.

- **Decrease force:** turn counter-clockwise; 8 turns max.
- **Increase force:** turn clockwise; 14 turns max.

Depending on opening conditions, a door adjusted to meet barrier-free forces may not have sufficient power to reliably close and latch the door.

| Track mount |             |                       |            |            |
|-------------|-------------|-----------------------|------------|------------|
|             | Closer size | Max door weight (lbs) | Door width | Full turns |
|             |             |                       | Interior   |            |
| 8916        | 4           | 125                   | 2'-6"      | 0          |
|             | 5           | 150                   | 3'         | +4         |
|             | 6           | 200                   | 3'-6"      | +12        |
| 8956        | 6           | 200                   | 3'6"       | 0          |
|             | 6+          | 250                   | 4'         | 6+         |

## 4 Install covers

Fig.8

4.1.1 Place tab in cover slot, opposite main arm.

4.1.2 Place cover over closer and fasten securely with screws provided.

**Snap valve adjustment wrench inside cover.**

